

Material Specification	Grade 6082 T6 Aluminium Alloy
Loading Specification	For simply supported single X-Beams to Eurocode EN 1991-1/BS EN 8118. All load values are working loads. All load values are based on the compression chords restrained at 1.0m centres.

Overall Graded Results for Allowable Working Loads

Compression chord restraint at 1.0m intervals



		Span (m)						
		6	9	12	15	18		
Allowable Bending Moment	kNm	110	110	110	110	110	Weight	13.8kg/m
Allowable Shear (Load on vertical)	kN	50	50	50	50	50	Area	1188mm ²
							Ix	5.13x10 ⁸ mm ⁴
							Iy	2.9x10 ⁹ mm ⁴
							Cx	1348mm
							Cy	24.15mm
							E	7x10 ⁴ N/mm ²

Maximum allowable beam bending moment capacity has been verified by testing as per BS EN 1990 Annex D D7.2.

		Span (m)									
		6	9	12	15	18	21	24	27	30	
Uniformly distributed load	kN/m	24.4	10.9	6.1	3.9	2.7	2.0	1.5	1.2	1.0	
Total UDL	kN	146.7	97.8	73.3	58.7	48.9	41.9	36.7	32.6	29.3	
Single point load	kN	73.3	48.9	36.7	29.3	24.4	21.0	18.3	16.3	14.7	
Two point loads	Each kN	55.0	36.7	27.5	22.0	18.3	15.7	13.8	12.2	11.0	
Three point loads	Each kN	36.7	24.4	18.3	14.7	12.2	10.5	9.2	8.1	7.3	

- Notes:**
- Above allowable loads can be increased by 1.11 for wind load only cases.
 - The tables above for single and two point locations assume all loads are applied at beam node points.
 - The tables above for UDL and three point load conditions make an allowance for local bending.
 - If the restraint of the beam compression chords does not comply with 1.0m or 1.5m centres, further design checks are required.
 - Allowable loads take into account the self weight of the beam.
 - The tables above are based on the support conditions for the beams to occur at a beam node point. All beams are assumed simply supported.
 - Supporting calculations are based on BS EN 1999-1-2 A2.
 - Maximum single point load 15kN (to be positioned as close to the node as possible).
 - Factor of Safety 1.65.
 - Permissible loads calculated in accordance with EN 1999-1-1:2007 and obtained through physical testing to EN 12811 Part 3.
 - Restraint point must support both top and bottom booms at restraint location.

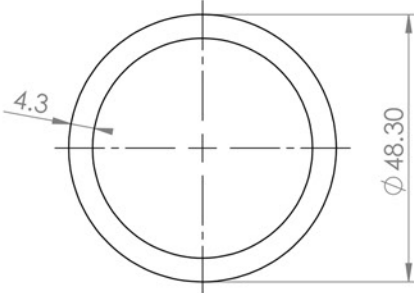
Additional Information	Our welders are qualified to: EN 287-1 AS/NZS 1665 2004 BS EN 9606-2 2004 ISO 5817 2007 Welding and material test certs available on request. Apollo Scaffold Services are accredited to EN 1090-1:2009+A1:2011 - Execution of steel structures and aluminium structures (0086-CPR-637568). The manufacture (including welding) of structural work in steel and aluminium up to and including Execution Class 2 (EXC 2) as defined in EN 1090-2 and EN 1090-3. Full set of calculations available on Apollo Scaffold Services website: apolloscaffoldservices.co.uk
Disclaimer	Apollo Scaffold Services Ltd. advise on using a qualified structural engineer to design any project using aluminium beams.

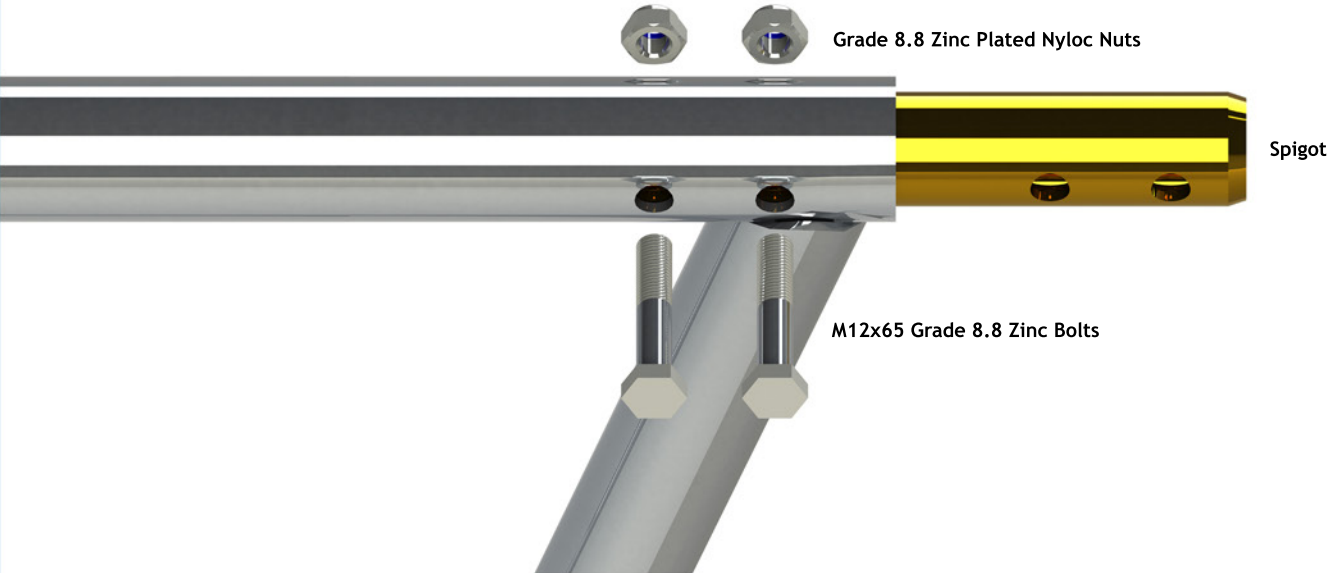
Material Specification	Grade 6082 T6 Aluminium Alloy
Dimension Specification	Tube: 48.3mm dia. x 4.2-4.4mm wall thickness
<div style="display: flex; justify-content: space-between; align-items: flex-start;"> <div style="width: 45%;">  </div> <div style="width: 45%; text-align: center;"> <p style="color: red; font-weight: bold;">If markings are not present then specification is invalid.</p>  <ol style="list-style-type: none"> 1. BS / EN Mark 2. Manufacturing date 3. Serial number </div> </div> <p>Main Boom, Verticals & Diagonals</p>	
Fixing Specification	M12x65 Grade 8.8 Zinc Plated Bolts and Nyloc Nuts
	
Additional Information	<p>Our welders are qualified to: EN 287-1 AS/NZS 1665 2004 BS EN 9606-2 2004 ISO 5817 2007 Welding and material test certs available on request.</p> <p>Apollo Scaffold Services are accredited to EN 1090-1:2009+A1:2011 - Execution of steel structures and aluminium structures (0086-CPR-637568). The manufacture (including welding) of structural work in steel and aluminium up to and including Execution Class 2 (EXC 2) as defined in EN 1090-2 and EN 1090-3. Full set of calculations available on Apollo Scaffold Services website: apolloscaffoldservices.co.uk</p>
Disclaimer	<p style="color: red; font-weight: bold;">Apollo Scaffold Services Ltd. advise on using a qualified structural engineer to design any project using aluminium beams.</p>

Key Dimensions	Dimensions of Beam and Spigot Connection
Standard Beam Lengths	580mm / 1000mm / 2000mm / 3000mm / 4000mm / 5000mm / 6000mm

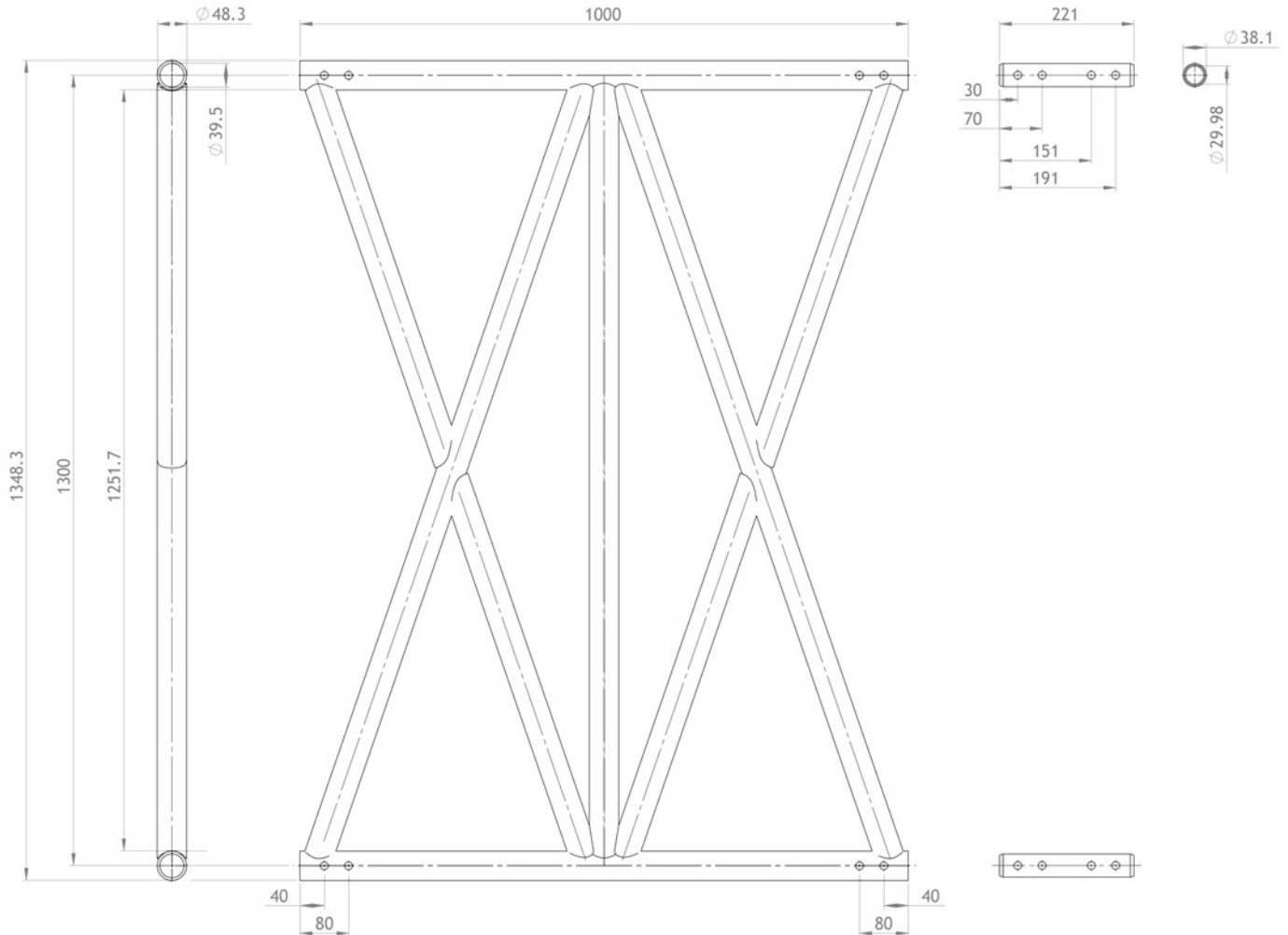

Spigot connections can be introduced at any location in a beam span and don't impact on the beam capacities quoted

Additional Information	<p>Our welders are qualified to: EN 287-1 AS/NZS 1665 2004 BS EN 9606-2 2004 ISO 5817 2007 Welding and material test certs available on request.</p> <p>Apollo Scaffold Services are accredited to EN 1090-1:2009+A1:2011 - Execution of steel structures and aluminium structures (0086-CPR-637568). The manufacture (including welding) of structural work in steel and aluminium up to and including Execution Class 2 (EXC 2) as defined in EN 1090-2 and EN 1090-3. Full set of calculations available on Apollo Scaffold Services website: apolloscaffoldservices.co.uk</p>
-------------------------------	--

Disclaimer	Apollo Scaffold Services Ltd. advise on using a qualified structural engineer to design any project using aluminium beams.
-------------------	---